

800-428-5655

[www.landoll.com/mhp](http://www.landoll.com/mhp)



**DREXEL**



# ***SLAC-2***

4-Wheel VNA Swing Mast™  
Electric Multi-Purpose  
Pallet Load Handler and  
Long Load Side Loader



***Material Handling  
Products***

The Landoll 4-Wheel Drexel Swing Mast™ AC powered VNA forklift maximizes cube utilization while providing front loader versatility. Operator comfort, 100% AC power and single joystick hydraulic controls offer convenient and efficient operation. The ability to store long loads as a sideloader increases this unit's versatility for long load handling.

## STANDARD FEATURES

- 3,000 lb. (1,361kg), 4,000 lb. (1,814kg) and 5,000 lb. (2,268kg) Capacity at 24" (600mm) Load Center
- Lift Heights to 374" (9.5M)
- 56" (1.4M) Stacking Aisle
- High Visibility 3-Stage or 4-Stage Mast
- 48 Volt CAN-Bus Electrical System
- Dual AC Traction Motor Controllers
- AC Hydraulic Motor Controller
- Hydraulic Power Steering by Main Hydraulic Pump (No Separate Power Steering Pump or Motor)
- Full Diagnostic Intelligent Display with Battery Discharge Indicator and Hour Meter
- Four-Wheel Design, Dual Front Wheel Planetary Drives and Heavy Duty Articulating Rear Steer Axle
- Right Side 16½" (419mm) Deep Long Load Deck
- Large Diameter Poly Drive (Rubber on SL30AC) and Poly Steer Tires
- 22" (559mm) of Mast Shift, Includes 3" (76mm) of Reach and 90° Right Side Mast Rotation
- Comfortable Seated Operation with Single Joystick Hydraulic and Directional Control on Armrest
- Mast Tilt of 3° Forward and 4° Back (Restricted to 1° Forward and 2° Back at 294" and Higher Lift Height)
- Adjustable Cloth Suspension Swivel Seat with Adjustable Armrests
- Adjustable Steering Column, Key Switch, Rear View Mirror, Horn, Seat Belt
- Safety Seat Switch and Retractable Seat Belts
- Hydraulic Front-Wheel Disc Brakes
- Horizontal Tilt Indicator
- 4-Post Adjustable Overhead Guard
- 40" (1,000mm) Long End Tapered Forks, 37" (940mm) Wide Carriage and 36" (914mm) High Load Backrest
- Provisions for RF Terminals
- Accepts Class II Attachments
- Easily Accessible Components for Low Cost Maintenance

## OPTIONAL FEATURES

- Non-Standard Fork Lengths
- LED Headlights, Flashing Light and Rear Safety Lights
- Back-Up Alarm
- Integral Fork Positioner
- Auxiliary Hydraulics
- Non-Marking Tires
- UL-583 Type EE Electrical Rating, FM Approved
- Vinyl Seat
- Fire Extinguisher
- Lazer Fork Height Indicator
- Camera with Operator Compartment Monitor
- 42" (1,067mm) Wide Fork Carriage
- Battery Compartment Roll Out Tray
- Wire Guidance Controls – Truck Mounted
- Long Load Handling Deck Mount
- Capable of Freezer Operation to -22°F (-30°C)

## MAST DIMENSIONS

Lowered Height Based on 5" Mast Underclearance

LIFT HEIGHT		LOWERED HEIGHT		* FREE LIFT	
Inches	Meters	Inches	Meters	Inches	Meters
<b>Triple (3-Stage) Mast SL30AC / SL40AC / SL50AC</b>					
188	4.78	85	2.16	49	1.24
198	5.03	89	2.26	53	1.35
216	5.49	97	2.46	61	1.55
223	5.66	100	2.54	64	1.63
242	6.15	109	2.77	73	1.85
258	6.55	117	2.97	81	2.06
272	6.91	123	3.12	87	2.21
296	7.52	131	3.33	95	2.41
312	7.92	134	3.40	98	2.49
323	8.20	140	3.56	104	2.64
360	9.14	158	4.01	122	3.10
374**	9.50	168	4.27	132	3.35
* Free Lift Based on 36" High Load Backrest					
** 374" (9.5M) Mast Available on SL50AC Only					
<b>Quad (4-Stage) Mast SL30AC / SL40AC</b>					
250	6.35	89	2.26	53	1.35
258	6.55	91	2.31	55	1.40
276	7.01	97	2.46	61	1.55
294	7.47	103	2.62	67	1.70
312	7.92	109	2.77	73	1.85
<b>Quad (4-Stage) Mast SL50AC</b>					
250	6.35	93	2.36	57	1.45
260	6.60	97	2.46	61	1.55
276	7.01	104	2.64	68	1.73
295	7.49	111	2.82	75	1.91
315	8.00	119	3.02	83	2.11
*Free Lift Based on 36" (914mm) High Load Backrest					

# 4-Wheel VNA Swing Mast™ Electric Multi-Purpose Pallet Load Handler and Long Load Side Loader

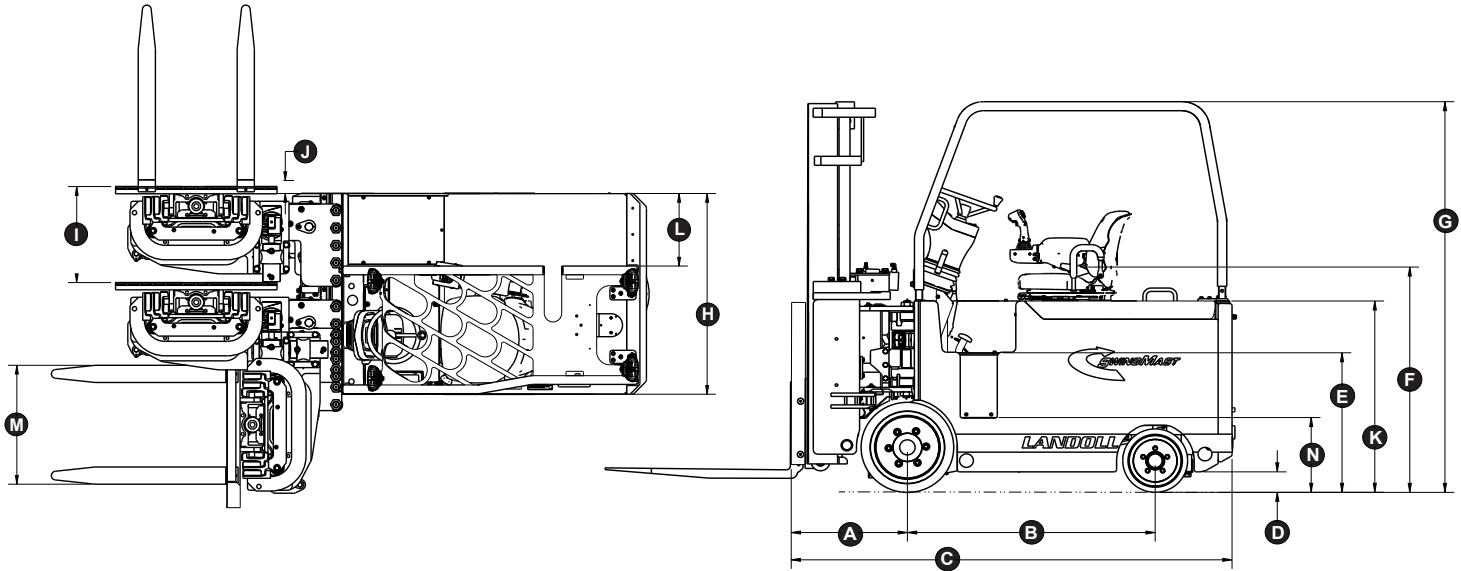

## TECHNICAL DATA

Capacity		lbs/kg	3,000 / 1,361	4,000 / 1,814	5,000 / 2,268
Load Center		in/mm	24 / 600	24 / 600	24 / 600
Weight	with Battery	lbs/kg	12,600 / 5,727	13,800 / 6,272	15,100 / 6,864
Travel Speed	Loaded	mph/kph	6.5 / 10.5	6.5 / 10.5	6.5 / 10.5
	Unloaded	mph/kph	7 / 11.3	7 / 11.3	7 / 11.3
Lift Speed	Loaded	fpm/mpm	90 / 27.4	90 / 27.4	90 / 27.4
	Unloaded	fpm/mpm	110 / 33.4	110 / 33.4	110 / 33.4
Lowering Speed	Loaded	fpm/mpm	100 / 30.5	100 / 30.5	100 / 30.5
	Unloaded	fpm/mpm	90 / 27.4	90 / 27.4	90 / 27.4
Mast Tilt	to 293" (7.44M)	fwd/back	3 / 4	3 / 4	3 / 4
	294" (7.46) and Higher	fwd/back	1 / 2	1 / 2	1 / 2
Mast Underclearance		in/mm	5 / 127	5 / 127	5 / 127
Lost Load Center	A with Triple Mast	in/mm	25 / 635	25 / 635	25 / 635
Wheelbase	B	in/mm	53.5 / 1,359	53.5 / 1,359	53.5 / 1,359
Overall Length	C with Triple Mast	in/mm	95.25 / 2,419	95.25 / 2,419	96.25 / 2,445
Rear Underclearance	D	in/mm	4.5 / 114	4.5 / 114	4.5 / 114
Cab Floor Height	E	in/mm	31 / 787	31 / 787	31 / 787
Seat Height	F	in/mm	50 / 1,270	50 / 1,270	50 / 1,270
Overhead Guard Height	G	in/mm	87 / 2,210	87 / 2,210	87 / 2,210
Chassis Width	H	in/mm	46 / 1,168	46 / 1,168	46 / 1,168
Mast Shift	I	in/mm	22 / 559	22 / 559	22 / 559
Side Reach	J	in/mm	3 / 76	3 / 76	3 / 76
Side Deck Height	K	in/mm	42.5 / 1,080	42.5 / 1,080	42.5 / 1,080
Side Deck Width	L	in/mm	16.5 / 419	16.5 / 419	16.5 / 419
Fork Carriage Width	M	in/mm	37 / 940	37 / 940	37 / 940
Step Height	N	in/mm	16.5 / 419	16.5 / 419	16.5 / 419
Fork Length		in/mm	40 / 1,016	40 / 1,016	40 / 1,016
Gradeability	Loaded	%	15	15	15
Hydraulic Motor Rating	Continuous Duty Rating	type/kWh	AC / 16.8	AC / 16.8	AC / 16.8
Traction Motor Rating	Continuous Duty Rating	type/kWh x 2	AC / 5.6 = 11.2	AC / 5.6 = 11.2	AC / 5.6 = 11.2
Drive Tire Type			Smooth Rubber	Smooth Poly	Smooth Poly
Drive Tire Size	Diameter x Width	in/mm	20x9 / 508x229	20x9 / 508x229	20x9 / 508x229
Steer Tires	Poly - Diameter x Width	in/mm	14x5 / 356x128	14x5 / 356x128	14x5 / 356x128

## AISLE DIMENSIONS

LOAD DEPTH X WIDTH	MINIMUM CLEAR AISLE
40" x 48" (1,000 x 1,200mm)	56" (1,422mm)
48" x 40" (1,200 x 1,000mm)	60" (1,524mm)
Minimum Clear Transfer Aisle with Load	138" (3,505mm)

## RECOMMENDED BATTERIES

<b>BATTERY DESIGNATION: 24-100-21, 48 VOLT, 1,000 AHC</b>
Battery Weight Min. 3,250 lbs. (1,477kg) - Max. 3,900 lbs. (1,773kg)
Leads are at Position A, 36" (91.4cm) Long, with SB 350 Amp Blue Connector
Nominal Size: 33" x 38.5625" x 25.625" (84 x 98 x 65cm)
Compartment Size: 33.5" x 38.625" x 25.75" (85 x 98 x 65cm)

# Quality Narrow Aisle Lift Trucks for Space Optimization



Removable Cover Provides Easy Access to All Control Components



Long Load Handler



Dash Display with Full Diagnostics, Hour Meter and Battery Discharge Indicator



Single Joystick Controls for All Hydraulic Functions, Directional Control and Horn



**MATERIAL HANDLING**  
*landoll.com/mhp*

1900 North Street · Marysville, KS 66508 · 800-428-5655 · forkliftsales@landoll.com

Landoll continuously improves products. We reserve the right to make any changes in illustrations, specifications, equipment, and prices without prior notice and without changes on previous models.



Intertek

