

# DREXEL®



## **SL120**

**SWINGMAST® Lift Truck**

**Electric Multi-Purpose 12,000 LB. (5,443KG) Capacity**

### **STANDARD FEATURES**

- Four Wheel Design, Front Wheel Drive, Rear Wheel Steering
- High Visibility 3-Stage Mast
- 72 Volt Electrical System
- Safety Seat Switch and Retractable Seatbelt
- Front-Wheel, Self-Adjusting Wet Disc Brakes
- Hand Actuated Parking Brake
- GE "SCR" Controls
- Adjustable Steering Column with Battery Discharge Indicator and Hour Meter
- Type "E" Construction
- Hydrostatic Power Steering
- Automatic Return-to-Neutral
- Locking Differential
- Load Backrest
- Horizontal Tilt Indicator
- Polyurethane Drive & Steer Tires

### **OPTIONAL FEATURES**

- Type "EE" UL Construction
- LED Headlights, Flashing Light, and Rear Safety Lights
- Backup Alarm
- Fire Extinguisher
- Long Load Handling Deck Mount
- Lift Limit
- Integral Fork Positioner
- Non-Standard Fork Lengths
- Auxiliary Hydraulics
- "X" Groove Polyurethane Drive & Steer Tires

**LANDOLL CORPORATION**  
**[www.landoll.com/mhp](http://www.landoll.com/mhp) | 800-428-5655**



## TECHNICAL DATA

MODEL			SL120
Capacity		lbs/kg	12,000 / 5,443
Voltage			72
Load Center		in/mm	24 / 610
Weight with Battery		lbs/kg	29,100 / 13,199
Travel Speed	Loaded	mph/kph	5 / 8.05
	Unloaded	mph/kph	6 / 9.65
Lift Speed	Loaded (5,500 lbs/2,495 kg)	fpm/mpm	30 / 9
	Unloaded	fpm/mpm	40 / 12
Lower Speed	Loaded	fpm/mpm	80 / 24
	Unloaded	fpm/mpm	35 / 11
Mast Tilt	Forward / Backward	deg	3 / 6
Mast Underclearance		in/mm	8 / 203
Lost Load Center	A with Triple Mast	in/mm	30 / 762
Wheel Base	B	in/mm	59 / 1,499
Overall Length	C	in/mm	117 / 2,972
Underclearance	D	in/mm	5 / 127
Step Height	E	in/mm	18 / 457
Cab Floor Height	F Lowest Point	in/mm	32 / 813
Side Deck Height	G	in/mm	44 / 1,118
Overhead Guard Height	H	in/mm	91 / 2,311
SIP to Bottom of OHG	I	in/mm	40 / 1,016
Overall Width	J	in/mm	69.5 / 1,765
Side Deck Width	K	in/mm	29 / 737
Fork Carriage Width	L	in/mm	54 / 1,372
Mast Shift	M	in/mm	44* / 1,118
Side Reach	N	in/mm	4 / 102
Turning Radius	O		106 / 2,692
Fork Length			42 / 1,067
Gradeability	Loaded	%	10
Tire Type	Drive / Steer		Poly / Poly
Tire Sizes	Drive	in/cm	22x14x16 / 56x36x41
	Steer	in/cm	16.2x8x11.2 / 41x20x28

# DREXEL SL120

SwingMast® | Electric Forklift Truck

## MAST DIMENSIONS

MAX. FORK HEIGHT		COLLAPSED HEIGHT		FREE LIFT HEIGHT*		MAX OVERALL HEIGHT	
In	M	In	M	In	M	In	M
135	3.43	82	2.08	42	1.07	177	4.50
153	3.89	88	2.24	48	1.22	195	4.95
168	4.27	94	2.39	54	1.37	210	5.33
178	4.52	98	2.49	58	1.47	220	5.59
193	4.90	104	2.64	64	1.63	235	5.97
207	5.26	110	2.79	70	1.78	249	6.32
233	5.92	120	3.05	80	2.03	275	6.99
243	6.17	124	3.15	84	2.13	285	7.24

Above Dimensions are Based on a 8" (203mm) Mast Underclearance

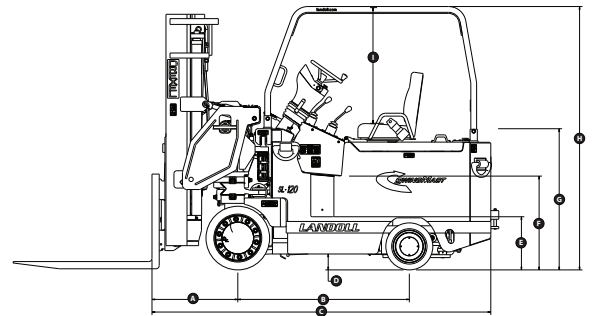

## RECOMMENDED BATTERY

BATTERY DIMENSIONS AND SPECIFICATIONS							
Volts	No. of Cells	ACH (6 Hr Rate) (amp Hr / kWh)	Weight (lbs / kg)		Width (in / mm)	Length (in / mm)	Height (in / mm)
			Min	Max			
72	36	765 / 55	4300 / 1950	4700 / 2131	38.38 / 975	44.38 / 1127	22.63 / 575
(2) 36	18	765 / 26.6	2140 / 971	2440 / 1106	19.31 / 490	44.31 / 1125	22.63 / 575
Max Allowable Battery Capacity per UL is 765 amp Hr (55 kWh)							
Battery Connector: 72 Volt - Green SBX 350; (2) 36 Volt - Grey SB 350							
Battery Lead: 72 Volt - Position "D", Length 36", Cable Size 2/0 AWG, with 36 Volt Tap (2) 36 Volt - Position "A", Length 36", Cable Size 2/0 AWG							
Battery Compartment Size: 45" x 39.75" x 22.75" (1143x1010x578mm)							

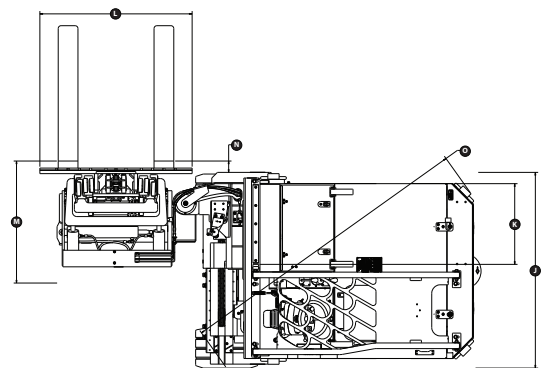

\*Shift with mast in 'front' position equals 22" (559mm).



[www.landoll.com/mhp](http://www.landoll.com/mhp)

DREXEL

1900 North Street | Marysville, KS 66508 | (800) 428-5655



SL120-1216