

COMBi-CBE8

The innovative Combi-CBE8 is designed to increase productivity, improve safety and help increase your storage capacity both indoors & outdoors.

COMBiLiFT

LIFTING INNOVATION



COMBI-CBE8

FRONTAL MODE

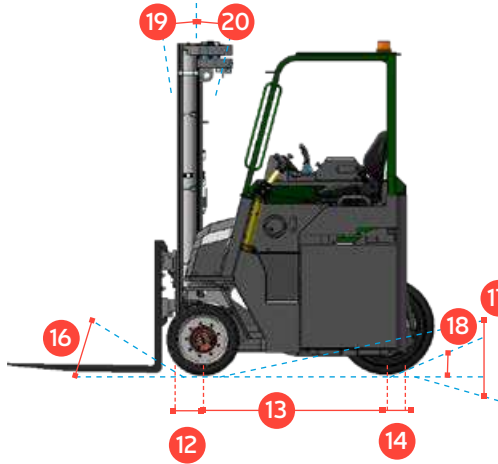

SIWARD MODE

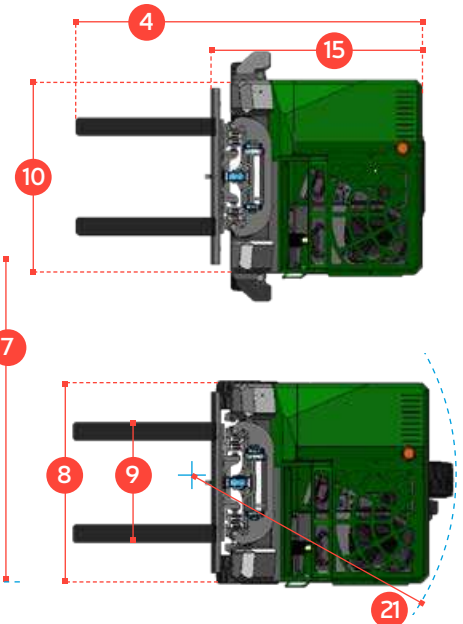
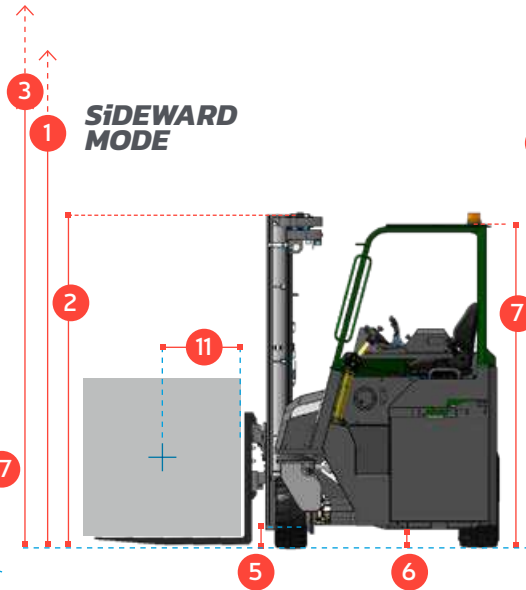

REF. DESCRIPTION

STANDARD

1a	Standard Lift Height	159"
1b	Free Lift Height	0"
2	Height Mast Closed	114"
3	Max. (Mast raised)	199"
4	Overall Length	114"
5	Ground Clearance Under Mast	6"
6	Ground Clearance to Wheelbase Centre	5"
7	Height of Overhead Guard	92 3/4"
8	Width	65"
9	Outside Spread of Fork Arms	59"
10	Track Front	55"
11	Load Centre Distance	23 1/2"
12	Overhang Front	14 1/3"
13	Wheelbase	53"
14	Overhang Back	6"
15	Length From Face of Fork	73 1/2"
16	Approach Angle	30°
17	Ramp Angle	20°
18	Departure Angle	30°
19	Forward Tilt	3°
20	Backward Tilt	7°
21	Minimum Outside Radius	65 3/4"
A	Capacity	8000 lbs
B	Unladen Weight	19275 lbs
C	Maximum Ground Speed	7 m/h
D	Gradeability	10%
E	Battery Capacity	72 V / 775 Ah
F	AC Electric Traction Motor x 3	4 hp (front) / 6.7 hp (rear)
G	AC Electric Pump Motor	25.5 hp
H	Fork Section	6 x 2 x 42
I	21 x 9 x 15 Front Tyre x 2 (Solid Rubber)	OD 21 / Width 9
J	28 x 12.5 x 15 Rear Tyre x 1 (Super Elastic Rubber)	OD 28 / Width 12.5
K	Standard Colour	Green and Grey
L	Suspension Seat	Grammer MSG 65

Multi-Directional



Features Include:

- Open cabin
- Load sensing steering
- 4-Way lever positioning of wheels
- System Communication via CAN-BUS
- Multi-directional operation
- 3 wheel electric drive
- Powered by AC technology

Distributed by:

Patents - Load Carrying Trucks - Australian Patent No. 2014217777; Brazilian Patent Application No. BR 11 2015 020348 5; Canadian Application No. 2,901,522; Chinese Patent No. ZL 201480009365.9; European Patent No. 2956350; German Patent No. 60 2010 037 116.6; Indian Patent Application No.2438/MUMNP/2015; United States - United States Patent No. 9,561,943;

Design Registration - Canada - Canadian Design Registration No. 123292; Switzerland - Swiss Design Registration No. 134.557; Europe - European Design Registration No. 00725668-0001; Japan - Japanese Design Registration No. 1330896; South Korea - South Korean Design Registration No. 30-0516087; Russian Federation - Russian Design Registration No. 70814; Taiwan - Taiwanese Design Registration No. D126056; USA - US Design Patent No. D579,624;

COMBILIFT HAS A POLICY OF CONTINUOUS PRODUCT DEVELOPMENT AND RESERVES THE RIGHT TO ALTER SPECIFICATIONS WITHOUT PRIOR NOTICE. SPECIFICATIONS AND/OR DIMENSIONS MAY VARY FROM THOSE ILLUSTRATED IN SOME COUNTRIES.

303 CONCORD STREET
GREENSBORO,
NORTH CAROLINA

TOLL FREE: 1-877 COMBI 56
TEL: 336-378-8884
INFO@COMBILIFT.COM

combilift.com