

ERGONOMIC POWER PLAYER



 **TORA-MAX**

COMPACT ELECTRIC WALKIE PALLET JACK

You work hard day-in and day-out. You deserve a reliable piece of equipment that can amp up your productivity, and the Tora-Max Compact Electric Walkie Pallet Jack will work just as long as you do. This pallet jack delivers optimal maneuverability and exceptional power to keep your operation running smoothly. Its compact design allows for seamless navigation when working on trailers and in crowded areas. Restocking shelves on sales floors or maneuvering pallet loads in stockrooms is made easy with the Compact Tora-Max.

UP TO
4500 LB.
CAPACITY

LITHIUM-ION
BATTERY



ADVANTAGES

- **EXCHANGEABLE LITHIUM-ION BATTERY** allows for fast charging and quick, easy battery replacement
- **U-SHAPED FORK DESIGN** provides easy pallet entry and exit, especially when empty
- **TURTLE SPEED BUTTON** slows the maximum operating speed for enhanced control and precision
- **LCD DISPLAY** shows battery usage and truck information such as fault codes and working hours
- **VERTICAL DRIVING POSITION** allows operators to use the truck in confined areas without having to fully extend the control handle
- **USER ACCESS CONTROL** utilizes large display buttons and reduces the likelihood of unauthorized use

The Tora-Max Compact Electric Walkie Pallet Jack is equipped with soft grip handles and conveniently placed directional thumb wheels to provide lasting operator comfort shift after shift. Including electric lift and lower and easy to reach directional buttons, the Compact Electric Walkie Pallet Jack provides smooth movement of forks with and without loads. One more reason Tora-Max is your next employee of the month.



EXCHANGE & GO BATTERY

If you thought this was just another walkie pallet jack, think again. The Tora-Max Compact Electric Walkie Pallet Jack features a cartridge-style lithium-ion battery for increased productivity and reduced downtime. With the option to charge the battery both inside and outside the truck, the simple-to-use charger gives you charging flexibility to carry out all of your operational tasks. An optional second battery pack allows for greater run time, so you can stay on the move.

ERGONOMICALLY POSITIONED FOR PRODUCTIVITY

The Tora-Max Compact Electric Walkie Pallet Jack is easy-to-use and designed with your operation's productivity in mind so you can get your equipment on the floor and get to work. This pallet jack features an easy-to-reach control handle, turtle button, pin code panel, and electric lift/lower buttons, that give you the ability to easily and comfortably reach the functions you need to get the job done. It's comfort and an intuitive design combined in one, because we believe handles should be designed for hands.



CAPACITY
3,300 OR 4,500 LBS.

LOAD CENTER
24 IN

MAXIMUM FORK HEIGHT
9.25 IN

INDUSTRIES



Beverage



General
Manufacturing



General
Warehousing



Distribution



Food
Storage



Retail

STANDARD EQUIPMENT

PERFORMANCE

- 24V electrical system³
- 48V electrical system⁴
- DC drive motor
- Exchangeable battery¹
- LCD display
- Regenerative braking
- Anti-roll back system

OPERABILITY & ERGONOMICS

- Multifunction control handle with ergonomic hand grips
- Fingertip controls of all functions
- Directional thumb wheels
- “Pinwheel” capability
- Turtle speed
- Electric lift and lower
- Pin code access w/ built-in keypad
- RFID access⁴
- Digital hour meter
- LCD battery discharge indicator w/ hour meter
- Parking brake

BODY/EXTERIOR DESIGN

- Polyurethane load wheels with sealed bearings
- Polyurethane drive tire
- Emergency power disconnect switch
- External battery charger (110V)
- Pallet entry rollers
- Stabilizing casters⁴
- Tapered fork tips w/ pallet entry slides

OPTIONAL EQUIPMENT

- 48” High load backrest²
- Caster wheel kit³
- Extra lithium-Ion battery

¹ Choice of 20Amp/Hr or 36Amp/Hr battery available for the 2TWB33. 2TWB45 is 36Amp/Hr only.

² Only one load backrest option can be ordered per truck.

³ Only available on 2TWB33.

⁴ Only available on 2TWB45.



TORA-MAX 2TWB33-45

GENERAL DATA				2TWB33	2TWB45
Load Capacity		lb [kg]		3300 [1500]	4500 [2045]
Power Type				Battery	Battery
Operator Position				Walkie	Walkie
Tire Type	Drive / Load			Polyurethane / Polyurethane	Polyurethane/Polyurethane
Wheels (x = driven)	Front / Rear			1 x / 2	1 (Drive) / 2 (Load) / 2 (Caster)
EXTERIOR DIMENSIONS ¹				2TWB33	2TWB45
A	Fork Length ¹	in [mm]		45.3 [1150]	45.3 [1150]
B	Overall Length ²	in [mm]		60.3 [1530]	60.5 [1536]
C	Wheelbase	Lowered	in [mm]	46.6 [1183]	46.8 [1189]
D	Load Wheel Location	Lowered	in [mm]	37.3 [948]	37.3 [948]
		Raised	in [mm]	35 [890]	35 [890]
E	Turning Radius		in [mm]	52.4 [1350]	52.6 [1336]
F	Overall Width		in [mm]	27 [685]	27 [685]
G	Control Handle Height	Fully Raised	in [mm]	45.7 [1160]	45.7 [1160]
H	Control Handle Height	Fully Lowered	in [mm]	27.6 [700]	27.6 [700]
I	Bumper to Drive Tire Center		in [mm]	5.7 [144]	5.7 [144]
J	Bumper Underclearance		in [mm]	1.8 [45]	1.8 [45]
K	Fork Width		in [mm]	6.3 [160]	6.3 [160]
L	Overall Fork Width ¹		in [mm]	27 [685]	27 [685]
M	Head Length		in [mm]	15 [380]	15.4 [391]
N	Fork Height	Lowered	in [mm]	3.15 [80]	3.15 [80]
		Raised	in [mm]	7.6 [193]	7.7 [195]
P	Lift		in [mm]	4.5 [115]	4.5 [115]
	Basic Right-Angle Stacking Aisle Width ³		in [mm]	82.2 [2000]	
	Gross Weight without Battery		lb [kg]	268 [122]	322 [146]
PERFORMANCE DATA				2TWB33	2TWB45
Travel Speeds	Full Load	mph [km/h]		2.9 [4.6]	2.7 [4.4]
	No Load	mph [km/h]		3.0 [4.8]	3.0 [4.8]
Lift Speeds	Full Load	ft/s [mm/s]		0.07 [15]	0.04 [12]
	No Load	ft/s [mm/s]		0.08 [22]	0.06 [19]
Gradeability	Full Load	%		4	7
	No Load	%		16	16
Tires	Number	Front / Rear		1/2	1/2
	Size [dia. x width]	Drive (front)	in [mm]	8.3 x 2.8 [210 x 70]	8.3 x 2.8 [210 x 75]
		Load (rear)	in [mm]	3.2 x 3.7 [80 x 93]	3.2 x 3.7 [80 x 93]
POWER SYSTEM				2TWB33	2TWB45
Battery	Amps Max	V / Ah		20 or 36	20
	Voltage	V		24	48
Battery Weight	Min	lb [kg]		10.1 [4.6]	16.5 [7.5]
Electric Motor- Drive	Max	hp [kW/h]		.87 [.65]	1.0 [0.75]
Control Type	Drive			DC - Speed Control	DC - Speed Control

1 All numbers are nominal. For more information please see your dealer.

2 Measurement with the handle in the vertical position.

3 Minimum Aisle Width for Right-Angle Stacking; Aisle widths have been given for a standard model. Add a minimum of 12" for maneuverability.

EXTERIOR DIMENSIONS

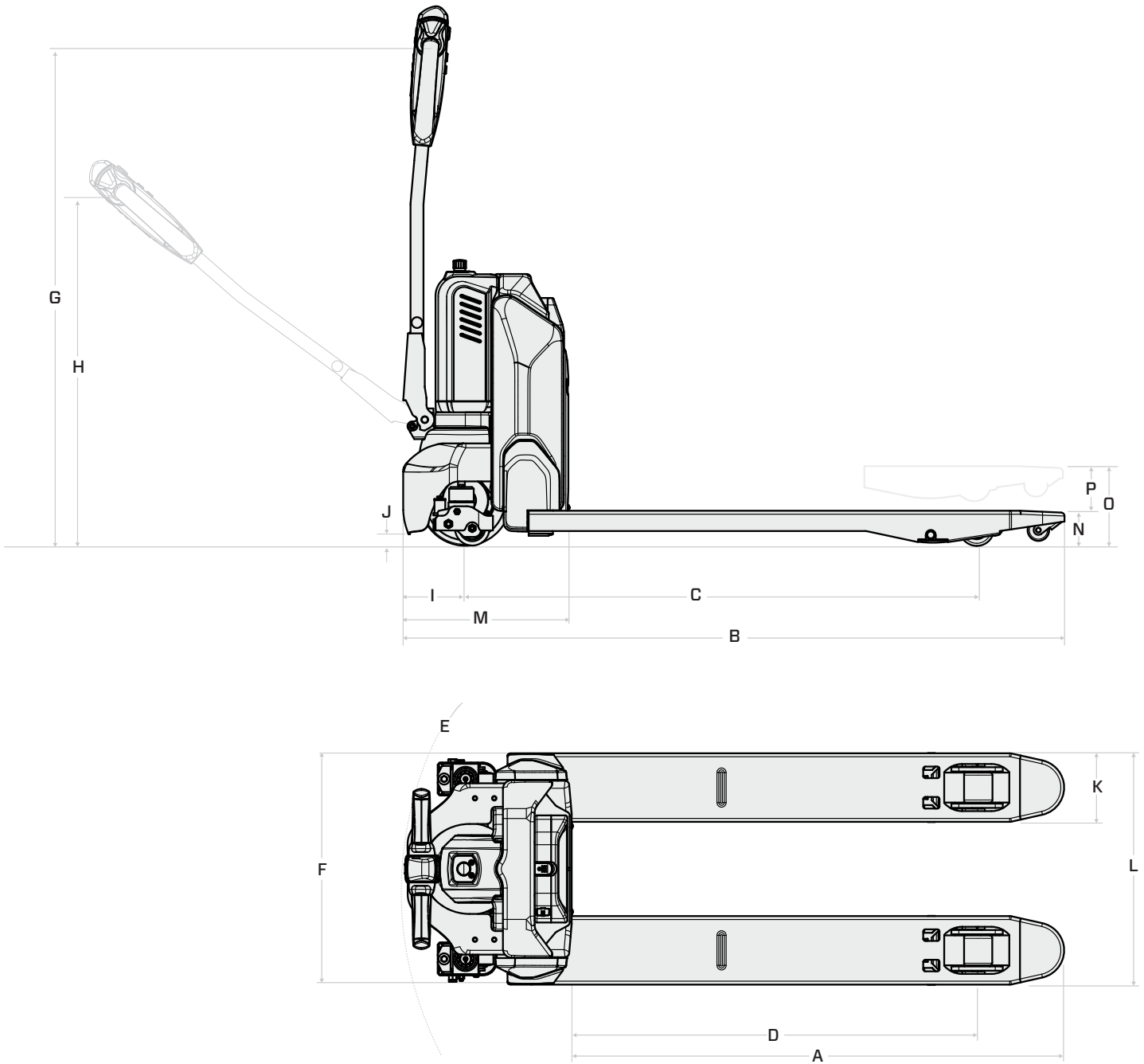



TORA-MAX

TORAMAXCOMPACTCOMP
©2023 TORA-MAX

shop.toyotaforklift.com

Some product features described herein are optional. Please consult your dealer for specifications. Details of specifications and equipment are based on information available at time of printing and may change without notice.