

INDOOR/OUTDOOR  
**MOVING MAST REACH TRUCK**



# A VERSATILE REACH TRUCK **SOLUTION**

- ▶ Up to 295" Lift Height
- ▶ Up to 3,500 lb. Capacity
- ▶ 360-degree or 180-degree Steering
- ▶ Interactive Touchscreen Display
- ▶ Fully Adjustable Operator Compartment
- ▶ Transitional Lift Control



RRE160HR

CLASS  
**2**

ELECTRIC MOTOR NARROW AISLE

[ToyotaForklift.com](http://ToyotaForklift.com)

# A PARTNER YOU CAN COUNT ON INDOOR OR OUT

UP TO **295** IN.  
LIFT HEIGHT

## **TOYOTA'S INDOOR/OUTDOOR MOVING MAST REACH TRUCK**

is in a class all its own when it comes to productivity, performance, and efficiency. These powerful lifts are equipped with innovative ergonomics and technology and offer clear and precise control for fast and smooth handling shift after shift. Whether you're operating indoors or out, the Toyota Indoor/Outdoor Moving Mast Reach Truck is the perfect lift to fit your operation's needs.



# THE FUNCTIONALITY YOU NEED. THE FLEXIBILITY YOU WANT.

---

The Indoor/Outdoor Moving Mast Reach Truck offers complete versatility for both indoor and outdoor applications due to the diameter of its durable wheels, high ground clearance, and multiple weather protection options to enhance driver comfort.

Designed with the operator in mind, an optional panoramic roof combined with the mast design offers the operator superb upward visibility with minimal load view obstruction.

Operators will love the fully adjustable compartment, featuring an adjustable seat, control handle, armrest, and more. An adjustable operator compartment floor improves driver ergonomics and an optional air-suspension seat makes sure operators can comfortably complete their heavy lifting.

Warehouses continue to build upward due to space constraints. The Toyota Indoor/Outdoor Moving Mast Reach Truck allows this same process to be applied to an outdoor storage area, providing for more efficient utilization of your real estate. The Indoor/Outdoor Moving Mast Reach Truck increases productivity and visibility at high heights with an innovative mast design and an optional transparent overhead guard that delivers true vision.





Interactive touchscreen display

## INTERACTIVE TOUCHSCREEN DISPLAY

The Indoor/Outdoor Moving Mast Reach Truck comes standard with an intuitive touchscreen display that includes optional functions like lift height and warnings for overload.

### Driver Control

- Automatic speed control, optional fork leveling, and centering.

### Optional Lift Mode

- Driver will get continuous updates on lift height, load weight indication, and fork alignment

Customizable performance and operating characteristics to meet your operation's needs

INDOOR/OUTDOOR

# MOVING MAST REACH TRUCK

## ADVANTAGES

▶ **AT YOUR FINGERTIPS**

A right-hand control unit allows the operator to choose between fingertip controls or multifunction controls to maximize productivity and comfort

---

▶ **NEXT LEVEL COMFORT**

The optional air-ride suspension seat ensures operator comfort. Easily adjust the floor height of the operator compartment to further improve driver ergonomics

---

▶ **TRANSITIONAL LIFT CONTROL**

provides shock-free lifting and lowering, allowing operators to maintain maximum load-handling speeds

---

▶ **360-DEGREE STEERING OPTION**

The continuous steering wheel movement without end positions enables smooth and fast maneuvering and change of direction

---



# TOYOTA MOVES WITH YOU



## A NAME YOU CAN TRUST

Our material handling equipment carries something no others can: The Toyota name. As one of the most recognized and respected global brands, the Toyota name is synonymous with quality, durability, and value. It also provides a peace of mind that few companies of any kind can match.

Every Toyota Forklift is built using the world-renowned Toyota Production System (TPS), which features Just-in-Time parts delivery and quality checks at every step of the manufacturing process.

It's all part of the Toyota philosophy of "kaizen," the dedication to continuous improvement. Instituted by our founder more than 80 years ago, it's a principle that still guides us today. As long as our forklifts carry the Toyota name, we'll continue striving to improve processes and quality.

## THE TOYOTA 360 SUPPORT PROMISE

In addition to moving more pallets more quickly through your facility, you can count on Toyota's dedication to quality and world-renown manufacturing methods to deliver unprecedented uptime and lower maintenance costs. Toyota 360 Support comes standard with every Toyota Reach Truck, meaning you benefit from an industry-leading two-year parts warranty, the support of over 65 dealerships, 3500+ Toyota Certified Technicians, and guaranteed 4-hour emergency response time.

**65+**  
DEALERSHIPS

**3500+**  
TOYOTA CERTIFIED TECHNICIANS

4-HOUR  
**GUARANTEED**  
EMERGENCY RESPONSE TIME

# INDOOR/OUTDOOR MOVING MAST REACH TRUCK

CAPACITY  
**3500 LBS.**

LOAD CENTER  
**24 IN.**

MAXIMUM FORK HEIGHT  
**295 IN.**

## INDUSTRIES

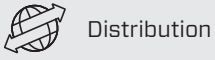

Distribution



Food Processing



General Manufacturing



Retail



Factory



Food Storage



General Warehousing

## STANDARD EQUIPMENT

### PERFORMANCE

- 48 Volt Electrical System
- AC Powered Drive System
- AC Hydraulic System
- Variable Speed Lift and Lowering
- Electric Power Steering
- Current-Controlled Proportional Valve
- Lowering Flow Limiter
- Lift System Relief Valve
- Optimized Cornering Control
- Optimized Reach Control
- Interactive Digital Display Panel
  - Multifunctional Hour Meter
  - Time & Date Display
  - Programmable Travel and Acceleration Speeds
  - Lift/Lower Speeds
  - Fault Code Memory

### OPERABILITY

- Selectable 360-degree or 180-degree Electronic Power Steering
- Wide-View 3-Stage Mast (FSV)
- View-through Carriage
- 35.4 in. Base Leg Opening (ID)
- Rubber Pneumatic-shaped Drive Tire (17.9 in. dia. x 6.3 in.)
- Rubber Pneumatic-shaped Load Wheels (17.9 in. dia. x 6.3 in.)
- Regenerative Braking
- 39.4 in. Load Backrest Extension
- ITA Class II Hook-Type Carriage (31 in. Wide)
- Forks: 1.57 in. x 4 in. x 45.28 in.
- Proportional Plugging
- Transitional Lift Control
- Steering Direction Indicator

### ERGONOMICS

- Seated Operator Compartment
- Manually Adjustable Height Floor
- Adjustable Armrest with Fingertip Controls
- High Visibility Overhead Guard
- Adjustable Steering Wheel

### SERVICEABILITY

- Battery Extraction by Mast
- Euro-style Battery Connector
- Battery Discharge Indicator w/ Lift Interrupt
- Self Diagnostics
- Built-In Analyzer
- Over Temperature Indicator w/ Protection
  - On Drive & Lift Motor
- Electric Disc Brake
- Emergency Power Shut-Down
- Electric Horn
- Operator PIN Code Access
- Enclosed Battery Compartment:
  - 13.7 in. x 47.7 in. x 30.9 in.

## OPTIONS AVAILABILITY CHART

### LOAD HANDLING

- Standard Fork Length, 45 in.
- Remove Forks
- Various Load Backrest Extensions
- Fork Carriage Prep for Attachment
- Optional Fork Tilt, 0.5° Fwd / 4° Bwd
- Various Auxiliary Function and Hosing Options

### BATTERY COMPARTMENT

- Various Battery Exchange and Cable Options

### BODY

- Transparent Overhead Guard
- Steel Mesh Mast Guard, Steel Mesh
- Overhead Guard Cover

### PERFORMANCE

- High Performance Lift Speed

### COMFORT & OPERABILITY

- Fingertip Lever Control
- Various Seat and Backrest Heights
- Adjustable Arm Rest
- Hip Side Bolster
- Electric Power Floor Height Adjustment
- Automatic Tilt Centering
- Automatic Sideshift Centering
- Integral Side Shifter (3 in. each way)

### LIGHTS, INDICATORS, & MISCELLANEOUS

- Various LED Work Light Options
- Various Strobe Light Options
- Height Indicator
- Load Information Display
- Overload Warning System
- Auto Height Select
- Lift Limit with Override
- Fork-mounted Camera System
- Mast-mounted Camera System
- Rear View Mirror
- Turn Signal Lights
- 2 Bluetooth Speakers
- Horizontal Accessory Bar
- Mounting Bracket for Inventory Computer Keyboard
- Mounting Bracket for Inventory Computer
- Transparent Clipboard
- Various Power Supply Options
- Small Item Holder, Single
- Small Item Holder, Double
- Scanner Holder
- Fire Extinguisher
- Programmable Travel Alarm
- Service Meter Setting
- Drive Motor Cooling Fans for High-Temp Applications
- Spring-loaded, Adhesive-backed Paper Clip

TRUCK SPECIFICATIONS

GENERAL DATA				MODEL NUMBERS	
				RRE160HR	
Load Capacity <sup>1</sup>		lb (kg)		3500 (1600)	
Load Center		in (mm)		24 (600)	
Battery Compartment Size				13.7	
Power Type				Battery	
Operator Position				Rider Seated	
EXTERIOR DIMENSIONS				RRE160HR	
<b>A</b> Fork Lowered Height		in (mm)		2.2 (55)	
<b>B</b> Maximum Fork Height (MFH) <sup>1</sup>		in (mm)		295.3 (7500)	
<b>C</b> Free Lift		in (mm)		101.2 (2571)	
<b>D</b> Tilt Range	Fwd/Bwd	deg		2 / 4	
<b>E</b> Mast Lowered Height <sup>1</sup>		in (mm)		123 (3124)	
<b>F</b> Mast Extended Height <sup>1</sup>		in (mm)		319.3 (8111)	
<b>G</b> Overhead Guard Height		in (mm)		91.7 (2330)	
<b>H</b> Fork Carriage Height		in (mm)		21.4 (544)	
<b>I</b> Seat Height		in (mm)		49.9 (1268)	
<b>J</b> Optional Battery Roller Height		in (mm)		16.9 (428)	
<b>K</b> Wheelbase		in (mm)		55.9 (1421)	
<b>L</b> Underclearance (center of wheelbase)	No Load	in (mm)		5.7 (145)	
<b>M</b> Head Length (Length to Fork Face)		in (mm)		52.9 (1344)	
<b>N</b> Truck Length (Length to End of Forks)		in (mm)		76.1 (1933)	
<b>O</b> Fork Size	T x W x L	in (mm)		1.57 x 4 x 45.28 (40 x 100 x 1150)	
<b>P</b> Fork Adjustment	Min./Max.	in (mm)		9.9 / 27.5 (252 / 698)	
<b>Q</b> Base Leg Inside Dimension (ID)		in (mm)		35.4 (900)	
<b>R</b> Base Leg Outside Dimension (OD)		in (mm)		55.7 (1414)	
<b>S</b> Truck Mast Overall Width		in (mm)		28.2 (716)	
<b>T</b> Overall Truck Width		in (mm)		55.7 (1414)	
<b>U</b> Outside Turning Radius		in (mm)		66.3 (1683)	
Reach Stroke		in (mm)		24.2 (614)	
Right Angle Stacking Aisle Width <sup>1</sup>				See Chart	
PERFORMANCE DATA				RRE160HR	
Speeds (Maximum)	Travel	Full Load	mph (km/h)	6.8 (11)	
		No Load	mph (km/h)	6.8 (11)	
	Lifting	Full Load	fpm (mm/sec)	70.9 (360)	
		No Load	fpm (mm/sec)	133.9 (680)	
	Lowering	Full Load	fpm (mm/sec)	116.1 (590)	
		No Load	fpm (mm/sec)	108.3 (550)	
	Reach / Retract	Full Load	sec	3.5	
		No Load	sec	2.6	
Gradeability	Full Load	%	10		
	No Load	%	15		
TRUCK WEIGHTS				RRE160HR	
Total Weight	Without Battery	lb (kg)		6234 (2827)	
TIRES				RRE160HR	
Tires	Tire Type	Drive/Load	Polyurethane/Rubber Pneumatic Shaped Cushion		
	Wheels (x = driven)	Drive/Load	1x / 2		
	Size (dia. X width)	Drive	in (mm)	18 x 6.1 (457 x 155)	
		Load	in (mm)	17.9 x 6.3 (455 x 160)	
Brake Type			Electric Disc		
POWER SYSTEM				RRE160HR	
Battery Type			Lead Acid		
Battery (6-hour ratings) <sup>2</sup>	Battery Dimensions	Length	in (mm)	13.7 (347)	
		Width	in (mm)	47.7 (1212)	
		Height	in (mm)	30.9 (784)	
	Voltage/ Capacity	Maximum	V / Ah	48 / 620	
		Weight	Minimum	lb (kg)	1929 (875)
			Maximum	lb (kg)	2271 (1030)
Electric Motors	Drive	hp (kw)	14.1 (10.5)		
	Load Handling	hp (kw)	14.8 (11)		
Control Type	Drive		AC		
	Load Handling		AC		
	Power Steering		AC		

1 Please contact your local Toyota dealer for more information regarding specifications.  
 2 Battery case must match dimensions and designated case design for proper battery retention

## EXTERIOR DIMENSIONS

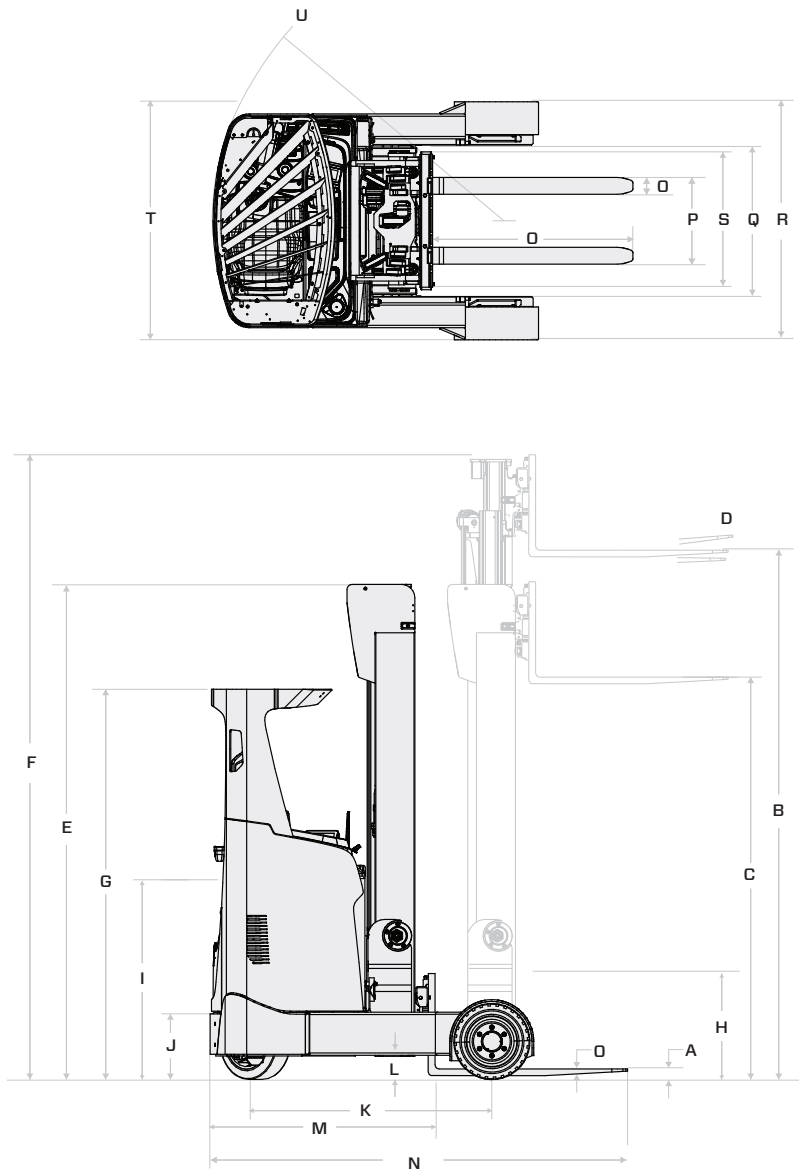

## MAST SPECIFICATIONS

MAST TYPE	MAXIMUM FORK HEIGHT (TOP OF FORKS)	OVERALL HEIGHT		FREE LIFT WITH STANDARD LOAD BACKREST	TILT RANGE	
		LOWERED	EXTENDED		FWD	BWD
			in (mm)	in (mm)		
<b>RRE160HR</b>						
Wide View Full-Free Lift Three-Stage Mast (FSV)	193 (4900)	89 (2257)	235 (5968)	49 (1245)	2	4
	213 (5400)	95 (2424)	255 (6469)	56 (1413)	2	4
	224 (5700)	99 (2524)	266 (6769)	60 (1513)	2	4
	248 (6300)	107 (2724)	290 (7369)	67 (1713)	2	4
	276 (7000)	116 (2957)	318 (8068)	77 (1945)	2	4
	285 (7250)	120 (3041)	328 (8320)	80 (2029)	2	4
	295 (7500)	123 (3124)	337 (8569)	83 (2113)	2	4

NOTE: Height of standard load backrest is 39.4 in (1000 mm).



# WORLD-CLASS MATERIAL HANDLING SOLUTIONS

**PARTNER WITH TOYOTA, AND LET US HELP DEVELOP THE RIGHT SOLUTION FOR YOU.**

With access to the world's industry-leading lineup of material handling products, Toyota dealers are uniquely positioned to help you solve your wide-ranging challenges. Built for every application, Toyota can provide the most complete set of solutions for material handling, automation, energy, advanced logistics, and warehouse optimization.

Toyota is here to help optimize your business for maximum efficiency. Utilizing Toyota Lean Management principles, Toyota dealers can provide insights and develop appropriate plans to tackle your specific operational needs. This unique approach to optimization and elimination of waste can provide you with significant competitive advantages and a sustainable lean culture for lasting process improvement.

**Visit us at: [ToyotaForklift.com](http://ToyotaForklift.com) for more information.**

